

Columns with Other Support Conditions

The problems for Section 11.4 are to be solved using the assumptions of ideal, slender, prismatic, linearly elastic columns (Euler buckling). Buckling occurs in the plane of the figure unless stated otherwise.

Problem 11.4-1 An aluminum pipe column ($E = 10,400$ ksi) with length $L = 10.0$ ft has inside and outside diameters $d_1 = 5.0$ in. and $d_2 = 6.0$ in., respectively (see figure). The column is supported only at the ends and may buckle in any direction.

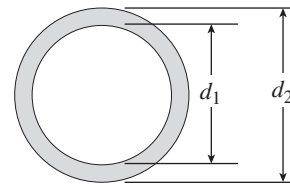

Probs. 11.4-1 and 11.4-2

Calculate the critical load P_{cr} for the following end conditions: (1) pinned-pinned, (2) fixed-free, (3) fixed-pinned, and (4) fixed-fixed.

Solution 11.4-1 Aluminum pipe column

$$d_2 = 6.0 \text{ in.} \quad d_1 = 5.0 \text{ in.} \quad E = 10,400 \text{ ksi}$$

$$I = \frac{\pi}{64}(d_2^4 - d_1^4) = 32.94 \text{ in.}^4$$

$$L = 10.0 \text{ ft} = 120 \text{ in.}$$

(1) PINNED-PINNED

$$P_{cr} = \frac{\pi^2 EI}{L^2} = \frac{\pi^2 (10,400 \text{ ksi})(32.94 \text{ in.}^4)}{(120 \text{ in.})^2} = 235 \text{ k} \quad \leftarrow$$

$$(2) \text{ FIXED-FREE} \quad P_{cr} = \frac{\pi^2 EI}{4L^2} = 58.7 \text{ k} \quad \leftarrow$$

$$(3) \text{ FIXED-PINNED} \quad P_{cr} = \frac{2.046 \pi^2 EI}{L^2} = 480 \text{ k} \quad \leftarrow$$

$$(4) \text{ FIXED-FIXED} \quad P_{cr} = \frac{4\pi^2 EI}{L^2} = 939 \text{ k} \quad \leftarrow$$

Problem 11.4-2 Solve the preceding problem for a steel pipe column ($E = 210$ GPa) with length $L = 1.2$ m, inner diameter $d_1 = 36$ mm, and outer diameter $d_2 = 40$ mm.

Solution 11.4-2 Steel pipe column

$$d_2 = 40 \text{ mm} \quad d_1 = 36 \text{ mm} \quad E = 210 \text{ GPa}$$

$$I = \frac{\pi}{64}(d_2^4 - d_1^4) = 43.22 \times 10^3 \text{ mm}^4 \quad L = 1.2 \text{ m}$$

$$(1) \text{ PINNED-PINNED} \quad P_{cr} = \frac{\pi^2 EI}{L^2} = 62.2 \text{ kN} \quad \leftarrow$$

$$(2) \text{ FIXED-FREE} \quad P_{cr} = \frac{\pi^2 EI}{4L^2} = 15.6 \text{ kN} \quad \leftarrow$$

$$(3) \text{ FIXED-PINNED} \quad P_{cr} = \frac{2.046 \pi^2 EI}{L^2} = 127 \text{ kN} \quad \leftarrow$$

$$(4) \text{ FIXED-FIXED} \quad P_{cr} = \frac{4\pi^2 EI}{L^2} = 249 \text{ kN} \quad \leftarrow$$

Problem 11.4-3 A wide-flange steel column ($E = 30 \times 10^6$ psi) of W 12 \times 87 shape (see figure) has length $L = 28$ ft. It is supported only at the ends and may buckle in any direction.

Calculate the allowable load P_{allow} based upon the critical load with a factor of safety $n = 2.5$. Consider the following end conditions:

(1) pinned-pinned, (2) fixed-free, (3) fixed-pinned, and (4) fixed-fixed.

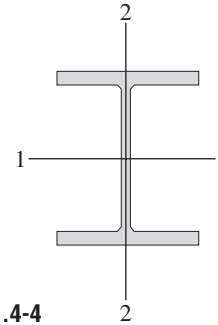

Probs. 11.4-3 and 11.4-4

Solution 11.4-3 Wide-flange column

$$W 12 \times 87 \quad E = 30 \times 10^6 \text{ psi}$$

$$L = 28 \text{ ft} = 336 \text{ in.} \quad n = 2.5 \quad I_2 = 241 \text{ in.}^4$$

(1) PINNED-PINNED

$$P_{\text{allow}} = \frac{P_{cr}}{n} = \frac{\pi^2 EI_2}{nL^2} = 253 \text{ k} \quad \leftarrow$$

(2) FIXED-FREE

$$P_{\text{allow}} = \frac{\pi^2 EI_2}{4nL^2} = 63.2 \text{ k} \quad \leftarrow$$

(3) FIXED-PINNED

$$P_{\text{allow}} = \frac{2.046\pi^2 EI_2}{nL^2} = 517 \text{ k} \quad \leftarrow$$

(4) FIXED-FIXED

$$P_{\text{allow}} = \frac{4\pi^2 EI_2}{nL^2} = 1011 \text{ k} \quad \leftarrow$$

Problem 11.4-4 Solve the preceding problem for a W 10 \times 60 shape with length $L = 24$ ft.

Solution 11.4-4 Wide-flange column

$$W 10 \times 60 \quad E = 30 \times 10^6 \text{ psi}$$

$$L = 24 \text{ ft} = 288 \text{ in.} \quad n = 2.5 \quad I_2 = 116 \text{ in.}^4$$

(1) PINNED-PINNED

$$P_{\text{allow}} = \frac{P_{cr}}{n} = \frac{\pi^2 EI_2}{nL^2} = 166 \text{ k} \quad \leftarrow$$

(2) FIXED-FREE

$$P_{\text{allow}} = \frac{\pi^2 EI_2}{4nL^2} = 41.4 \text{ k} \quad \leftarrow$$

(3) FIXED-PINNED

$$P_{\text{allow}} = \frac{2.046\pi^2 EI_2}{nL^2} = 339 \text{ k} \quad \leftarrow$$

(4) FIXED-FIXED

$$P_{\text{allow}} = \frac{4\pi^2 EI_2}{nL^2} = 663 \text{ k} \quad \leftarrow$$

Problem 11.4-5 The upper end of a $W 8 \times 21$ wide-flange steel column ($E = 30 \times 10^3$ ksi) is supported laterally between two pipes (see figure). The pipes are not attached to the column, and friction between the pipes and the column is unreliable. The base of the column provides a fixed support, and the column is 13 ft long.

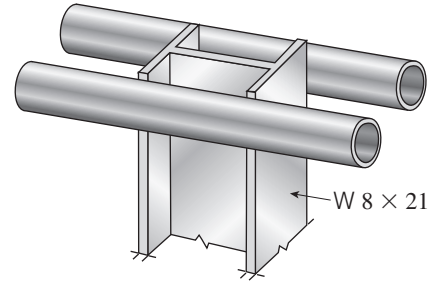

Determine the critical load for the column, considering Euler buckling in the plane of the web and also perpendicular to the plane of the web.

Solution 11.4-5 Wide-flange steel column

$W 8 \times 21 \quad E = 30 \times 10^3 \text{ ksi}$
 $L = 13 \text{ ft} = 156 \text{ in.} \quad I_1 = 75.3 \text{ in.}^4$
 $I_2 = 9.77 \text{ in.}^4$

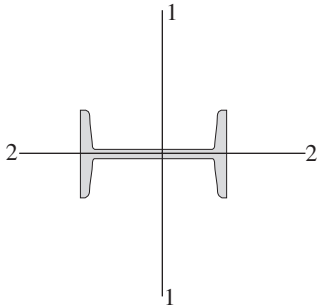

AXIS 1-1 (FIXED-FREE)

$$P_{cr} = \frac{\pi^2 EI_1}{4L^2} = 229 \text{ k}$$

AXIS 2-2 (FIXED-PINNED)

$$P_{cr} = \frac{2.046\pi^2 EI_2}{L^2} = 243 \text{ k}$$

Buckling about axis 1-1 governs.

$P_{cr} = 229 \text{ k} \quad \leftarrow$

Problem 11.4-6 A vertical post AB is embedded in a concrete foundation and held at the top by two cables (see figure). The post is a hollow steel tube with modulus of elasticity 200 GPa, outer diameter 40 mm, and thickness 5 mm. The cables are tightened equally by turnbuckles.

If a factor of safety of 3.0 against Euler buckling in the plane of the figure is desired, what is the maximum allowable tensile force T_{allow} in the cables?

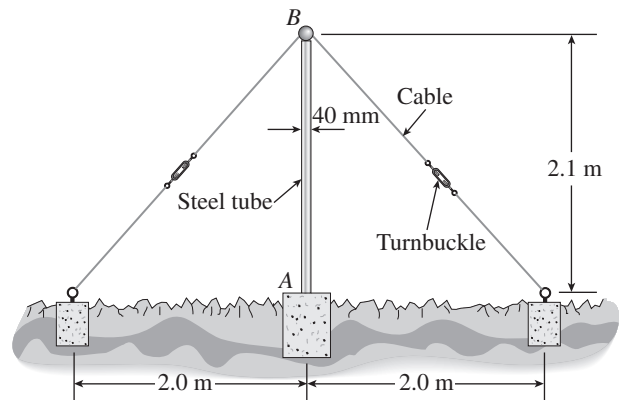

Solution 11.4-6 Steel tube

$E = 200 \text{ GPa} \quad d_2 = 40 \text{ mm} \quad d_1 = 30 \text{ mm}$
 $L = 2.1 \text{ m} \quad n = 3.0$

$$I = \frac{\pi}{64} (d_2^4 - d_1^4) = 85,903 \text{ mm}^4$$

Buckling in the plane of the figure means fixed-pinned end conditions.

$$P_{cr} = \frac{2.046\pi^2 EI}{L^2} = 78.67 \text{ kN}$$

$$P_{allow} = \frac{P_{cr}}{n} = \frac{78.67 \text{ kN}}{3.0} = 26.22 \text{ kN}$$

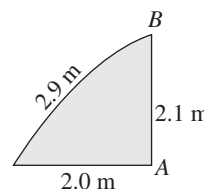

FREE-BODY DIAGRAM OF JOINT B

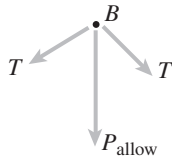
 T = tensile force in each cable P_{allow} = compressive force in tube

EQUILIBRIUM

$$\sum F_{\text{vert}} = 0 \quad P_{\text{allow}} - 2T\left(\frac{2.1 \text{ m}}{2.9 \text{ m}}\right) = 0$$

ALLOWABLE FORCE IN CABLES

$$T_{\text{allow}} = (P_{\text{allow}})\left(\frac{1}{2}\right)\left(\frac{2.9 \text{ m}}{2.1 \text{ m}}\right) = 18.1 \text{ kN} \quad \leftarrow$$

Problem 11.4-7 The horizontal beam ABC shown in the figure is supported by columns BD and CE . The beam is prevented from moving horizontally by the roller support at end A , but vertical displacement at end A is free to occur. Each column is pinned at its upper end to the beam, but at the lower ends, support D is fixed and support E is pinned. Both columns are solid steel bars ($E = 30 \times 10^6$ psi) of square cross section with width equal to 0.625 in. A load Q acts at distance a from column BD .

(a) If the distance $a = 12$ in., what is the critical value Q_{cr} of the load?

(b) If the distance a can be varied between 0 and 40 in., what is the maximum possible value of Q_{cr} ? What is the corresponding value of the distance a ?

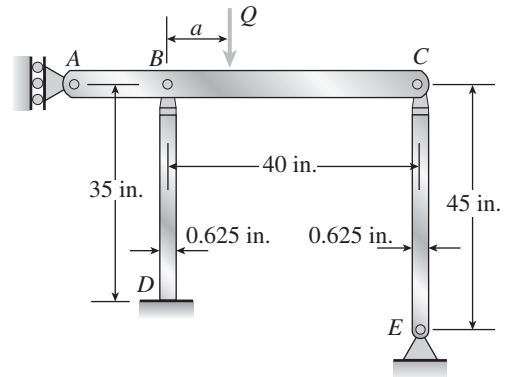
**Solution 11.4-7** Beam supported by two columnsCOLUMN BD $E = 30 \times 10^6$ psi $L = 35$ in.

$$b = 0.625 \text{ in.} \quad I = \frac{b^4}{12} = 0.012716 \text{ in.}^4$$

$$P_{\text{cr}} = \frac{2.046 \pi^2 EI}{L^2} = 6288 \text{ lb}$$

COLUMN CE $E = 30 \times 10^6$ psi $L = 45$ in.

$$b = 0.625 \text{ in.} \quad I = \frac{b^4}{12} = 0.012716 \text{ in.}^4$$

$$P_{\text{CR}} = \frac{\pi^2 EI}{L^2} = 1859 \text{ lb}$$

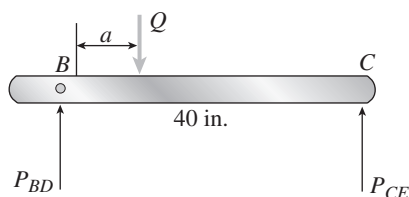
(a) FIND Q_{cr} IF $a = 12$ in.

$$P_{BD} = \frac{28}{40} Q = \frac{7}{10} Q \quad Q = \frac{10}{7} P_{BD}$$

$$P_{CE} = \frac{12}{40} Q = \frac{3}{10} Q \quad Q = \frac{10}{3} P_{CE}$$

$$\text{If column } BD \text{ buckles: } Q = \frac{10}{7} (6288 \text{ lb}) = 8980 \text{ lb}$$

$$\text{If column } CE \text{ buckles: } Q = \frac{10}{3} (1859 \text{ lb}) = 6200 \text{ lb}$$

$$\therefore Q_{\text{cr}} = 6200 \text{ lb} \quad \leftarrow$$

(b) MAXIMUM VALUE OF Q_{CR}

Both columns buckle simultaneously.

$$P_{BD} = 6288 \text{ lb} \quad P_{CE} = 1859 \text{ lb}$$

$$\sum F_{\text{vert}} = 0 \quad Q_{\text{CR}} = P_{BD} + P_{CE} = 8150 \text{ lb} \quad \leftarrow$$

$$\sum M_B = 0 \quad Q_{\text{CR}}(a) = P_{CE}(40 \text{ in.})$$

$$a = \frac{P_{CE}(40 \text{ in.})}{Q_{\text{CR}}} = \frac{(1859 \text{ lb})(40 \text{ in.})}{P_{BD} + P_{CE}}$$

$$= \frac{(1859 \text{ lb})(40 \text{ in.})}{6288 \text{ lb} + 1859 \text{ lb}} = 9.13 \text{ in.} \quad \leftarrow$$

Problem 11.4-8 The roof beams of a warehouse are supported by pipe columns (see figure on the next page) having outer diameter $d_2 = 100$ mm and inner diameter $d_1 = 90$ mm. The columns have length $L = 4.0$ m, modulus $E = 210$ GPa, and fixed supports at the base.

Calculate the critical load P_{cr} of one of the columns using the following assumptions: (1) the upper end is pinned and the beam prevents horizontal displacement; (2) the upper end is fixed against rotation and the beam prevents horizontal displacement; (3) the upper end is pinned but the beam is free to move horizontally; and (4) the upper end is fixed against rotation but the beam is free to move horizontally.

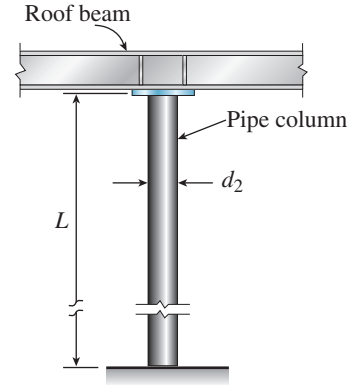

Solution 11.4-8 Pipe column (with fixed base)

$$E = 210 \text{ GPa} \quad L = 4.0 \text{ m}$$

$$d_2 = 100 \text{ mm} \quad I = \frac{\pi}{64} (d_2^4 - d_1^4) = 1688 \times 10^3 \text{ mm}^4$$

$$d_1 = 90 \text{ mm}$$

(1) UPPER END IS PINNED (WITH NO HORIZONTAL DISPLACEMENT)



$$P_{cr} = \frac{2.046\pi^2 EI}{L^2} = 447 \text{ kN} \quad \leftarrow$$

(2) UPPER END IS FIXED (WITH NO HORIZONTAL DISPLACEMENT)



$$P_{cr} = \frac{4\pi^2 EI}{L^2} = 875 \text{ kN} \quad \leftarrow$$

(3) UPPER END IS PINNED (BUT NO HORIZONTAL RESTRAINT)



$$P_{cr} = \frac{\pi^2 EI}{4L^2} = 54.7 \text{ kN} \quad \leftarrow$$

(4) UPPER END IS GUIDED (no rotation; no horizontal restraint)

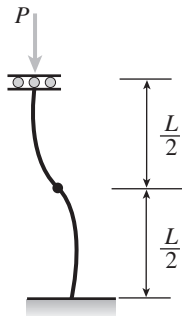

The lower half of the column is in the same condition as Case (3) above.

$$P_{cr} = \frac{\pi^2 EI}{4(L/2)^2} = \frac{\pi^2 EI}{L^2} = 219 \text{ kN} \quad \leftarrow$$

Problem 11.4-9 Determine the critical load P_{cr} and the equation of the buckled shape for an ideal column with ends fixed against rotation (see figure) by solving the differential equation of the deflection curve. (See also Fig. 11-17.)

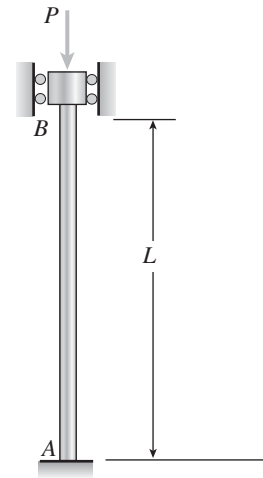

Solution 11.4-9 Fixed-end column

v = deflection in the y direction

DIFFERENTIAL EQUATION (EQ.11-3)

$$EIv'' = M = M_0 - Pv \quad k^2 = \frac{P}{EI}$$

$$v'' + k^2v = \frac{M_0}{EI}$$

GENERAL SOLUTION

$$v = C_1 \sin kx + C_2 \cos kx + \frac{M_0}{P}$$

$$\text{B.C. 1 } v(0) = 0 \quad \therefore C_2 = -\frac{M_0}{P}$$

$$v' = C_1 k \cos kx - C_2 k \sin kx$$

$$\text{B.C. 2 } v'(0) = 0 \quad \therefore C_1 = 0$$

$$v = \frac{M_0}{P}(1 - \cos kx)$$

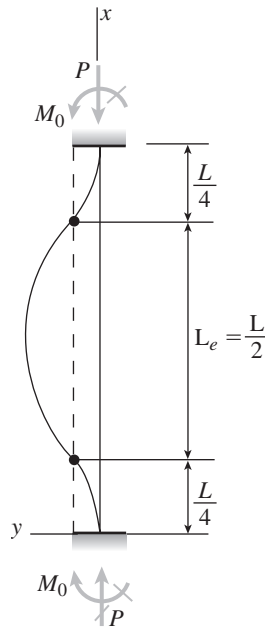

BUCKLING EQUATION

$$\text{B.C. 3 } v(L) = 0 \quad 0 = \frac{M_0}{P}(1 - \cos kL)$$

$$\therefore \cos kL = 1 \quad \text{and} \quad kL = 2\pi$$

CRITICAL LOAD

$$k^2 = \left(\frac{2\pi}{L}\right)^2 = \frac{4\pi^2}{L^2} \quad \frac{P}{EI} = \frac{4\pi^2}{L^2}$$

$$P_{cr} = \frac{4\pi^2 EI}{L^2} \quad \leftarrow$$

BUCKLED MODE SHAPE

Let δ = deflection at midpoint ($x = \frac{L}{2}$)

$$v\left(\frac{L}{2}\right) = \delta = \frac{M_0}{P}\left(1 - \cos \frac{kL}{2}\right)$$

$$\frac{kL}{2} = \pi \quad \therefore \delta = \frac{M_0}{P}(1 - \cos \pi)$$

$$= \frac{2M_0}{P} \quad \frac{M_0}{P} = \frac{\delta}{2}$$

$$v = \frac{\delta}{2}\left(1 - \cos \frac{2\pi x}{L}\right) \quad \leftarrow$$

Problem 11.4-10 An aluminum tube AB of circular cross section is fixed at the base and pinned at the top to a horizontal beam supporting a load $Q = 200$ kN (see figure).

Determine the required thickness t of the tube if its outside diameter d is 100 mm and the desired factor of safety with respect to Euler buckling is $n = 3.0$. (Assume $E = 72$ GPa.)

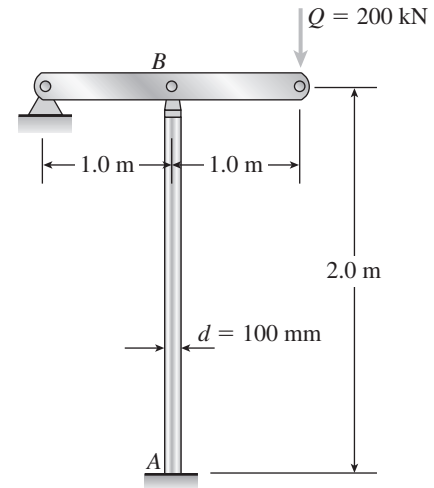

Solution 11.4-10 Aluminum tube

End conditions: Fixed-pinned

$$E = 72 \text{ GPa} \quad L = 2.0 \text{ m} \quad n = 3.0$$

$$d_2 = 100 \text{ mm} \quad t = \text{thickness (mm)}$$

$$d_1 = 100 \text{ mm} - 2t$$

MOMENT OF INERTIA (mm^4)

$$I = \frac{\pi}{64} (d_2^4 - d_1^4)$$

$$= \frac{\pi}{64} [(100)^4 - (100 - 2t)^4] \quad (1)$$

HORIZONTAL BEAM

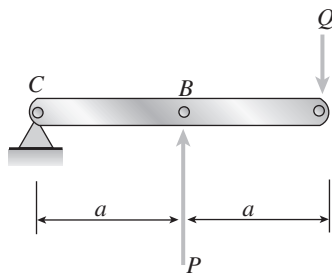

$$Q = 200 \text{ kN}$$

P = compressive force in tube

$$\sum M_c = 0 \quad Pa - 2Qa = 0$$

$$Q = \frac{P}{2} \quad \therefore P = 2Q = 400 \text{ kN}$$

ALLOWABLE FORCE P

$$P_{\text{allow}} = \frac{P_{\text{cr}}}{n} = \frac{2.046\pi^2 EI}{nL^2} \quad (2)$$

MOMENT OF INERTIA

$$I = \frac{nL^2 P_{\text{allow}}}{2.046\pi^2 E} = \frac{(3.0)(2.0 \text{ m})^2 (400 \text{ kN})}{(2.046)(\pi^2)(72 \text{ GPa})}$$

$$= 3.301 \times 10^{-6} \text{ m}^4 = 3.301 \times 10^6 \text{ mm}^4 \quad (3)$$

EQUATE (1) AND (3):

$$\frac{\pi}{64} [(100)^4 - (100 - 2t)^4] = 3.301 \times 10^6$$

$$(100 - 2t)^4 = 32.74 \times 10^6 \text{ mm}^4$$

$$100 - 2t = 75.64 \text{ mm} \quad t_{\text{min}} = 12.2 \text{ mm} \quad \leftarrow$$

Problem 11.4-11 The frame ABC consists of two members AB and BC that are rigidly connected at joint B , as shown in part (a) of the figure. The frame has pin supports at A and C . A concentrated load P acts at joint B , thereby placing member AB in direct compression.

To assist in determining the buckling load for member AB , we represent it as a pinned-end column, as shown in part (b) of the figure. At the top of the column, a rotational spring of stiffness β_R represents the restraining action of the horizontal beam BC on the column (note that the horizontal beam provides resistance to rotation of joint B when the column buckles). Also, consider only bending effects in the analysis (i.e., disregard the effects of axial deformations).

(a) By solving the differential equation of the deflection curve, derive the following buckling equation for this column:

$$\frac{\beta_R L}{EI} (kL \cot kL - 1) - k^2 L^2 = 0$$

in which L is the length of the column and EI is its flexural rigidity.

(b) For the particular case when member BC is identical to member AB , the rotational stiffness β_R equals $3EI/L$ (see Case 7, Table G-2, Appendix G). For this special case, determine the critical load P_{cr} .

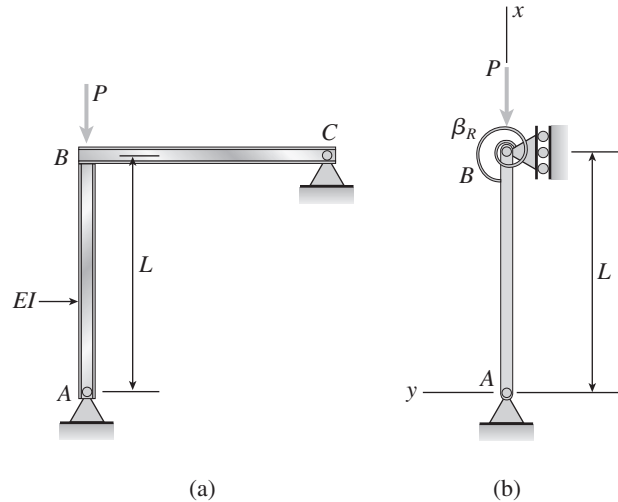

Solution 11.4-11 Column AB with elastic support at B

FREE-BODY DIAGRAM OF COLUMN

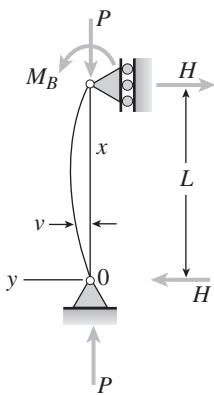

v = deflection in the y direction

M_B = moment at end B

θ_B = angle of rotation at end B (positive clockwise)

$M_B = \beta_R \theta_B$

H = horizontal reactions at ends A and B

EQUILIBRIUM

$$\sum M_0 = \sum M_A = 0 \quad M_B - HL = 0$$

$$H = \frac{M_B}{L} = \frac{\beta_R \theta_B}{L}$$

DIFFERENTIAL EQUATION (EQ. 11-3)

$$EIv'' = M = Hx - Pv \quad k^2 = \frac{P}{EI}$$

$$v'' + k^2 v = \frac{\beta_R \theta_B}{LEI} x$$

GENERAL SOLUTION

$$v = C_1 \sin kx + C_2 \cos kx + \frac{\beta_R \theta_B}{PL} x$$

$$\text{B.C. 1} \quad v(0) = 0 \quad \therefore C_2 = 0$$

$$\text{B.C. 2} \quad v(L) = 0 \quad \therefore C_1 = \frac{\beta_R \theta_B}{P \sin kL}$$

$$v = C_1 \sin kx + \frac{\beta_R \theta_B}{PL} x$$

$$v' = C_1 k \cos kx + \frac{\beta_R \theta_B}{PL}$$

(a) BUCKLING EQUATION

$$\text{B.C. 3} \quad v'(L) = -\theta_B$$

$$\therefore -\theta_B = -\frac{\beta_R \theta_B}{P \sin kL} (k \cos kL) + \frac{\beta_R \theta_B}{PL}$$

Cancel θ_B and multiply by PL :

$$-PL = -\beta_R kL \cot kL + \beta_R$$

Substitute $P = k^2 EI$ and rearrange:

$$\frac{\beta_R L}{EI} (kL \cot kL - 1) - k^2 L^2 = 0 \quad \leftarrow$$

(b) CRITICAL LOAD FOR $\beta_R = 3EI/L$

$$3(kL \cot kL - 1) - (kL)^2 = 0$$

Solve numerically for kL : $kL = 3.7264$

$$P_{cr} = k^2 EI = (kL)^2 \left(\frac{EI}{L^2} \right) = 13.89 \frac{EI}{L^2} \quad \leftarrow$$

Columns with Eccentric Axial Loads

When solving the problems for Section 11.5, assume that bending occurs in the principal plane containing the eccentric axial load.

Problem 11.5-1 An aluminum bar having a rectangular cross section (2.0 in. \times 1.0 in.) and length $L = 30$ in. is compressed by axial loads that have a resultant $P = 2800$ lb acting at the midpoint of the long side of the cross section (see figure).

Assuming that the modulus of elasticity E is equal to 10×10^6 psi and that the ends of the bar are pinned, calculate the maximum deflection δ and the maximum bending moment M_{\max} .

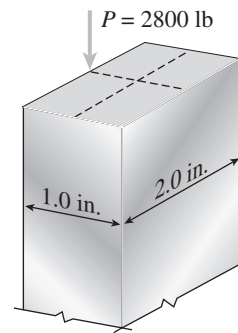

Solution 11.5-1 Bar with rectangular cross section

$$b = 2.0 \text{ in.} \quad h = 1.0 \text{ in.} \quad L = 30 \text{ in.}$$

$$P = 2800 \text{ lb} \quad e = 0.5 \text{ in.} \quad E = 10 \times 10^6 \text{ psi}$$

$$I = \frac{bh^3}{12} = 0.1667 \text{ in.}^4 \quad kL = L \sqrt{\frac{P}{EI}} = 1.230 \quad \leftarrow$$

$$\text{Eq. (11-51):} \quad \delta = e \left(\sec \frac{kL}{2} - 1 \right) = 0.112 \text{ in.} \quad \leftarrow$$

$$\text{Eq. (11-56):} \quad M_{\max} = Pe \sec \frac{kL}{2}$$

$$= 1710 \text{ lb-in.} \quad \leftarrow$$

Problem 11.5-2 A steel bar having a square cross section (50 mm \times 50 mm) and length $L = 2.0$ m is compressed by axial loads that have a resultant $P = 60$ kN acting at the midpoint of one side of the cross section (see figure).

Assuming that the modulus of elasticity E is equal to 210 GPa and that the ends of the bar are pinned, calculate the maximum deflection δ and the maximum bending moment M_{\max} .

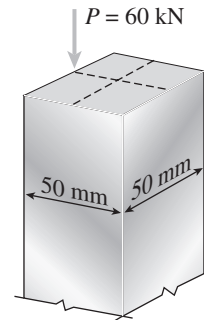

Solution 11.5-2 Bar with square cross section

$$b = 50 \text{ mm.} \quad L = 2 \text{ m.} \quad P = 60 \text{ kN} \quad e = 25 \text{ mm}$$

$$E = 210 \text{ GPa} \quad I = \frac{b^4}{12} = 520.8 \times 10^3 \text{ mm}^4$$

$$kL = L \sqrt{\frac{P}{EI}} = 1.481$$

$$\text{Eq. (11-51):} \quad \delta = e \left(\sec \frac{kL}{2} - 1 \right) = 8.87 \text{ mm} \quad \leftarrow$$

$$\text{Eq. (11-56):} \quad M_{\max} = Pe \sec \frac{kL}{2} = 2.03 \text{ kN} \cdot \text{m} \quad \leftarrow$$

Problem 11.5-3 Determine the bending moment M in the pinned-end column with eccentric axial loads shown in the figure. Then plot the bending-moment diagram for an axial load $P = 0.3P_{cr}$.

Note: Express the moment as a function of the distance x from the end of the column, and plot the diagram in nondimensional form with M/Pe as ordinate and x/L as abscissa.

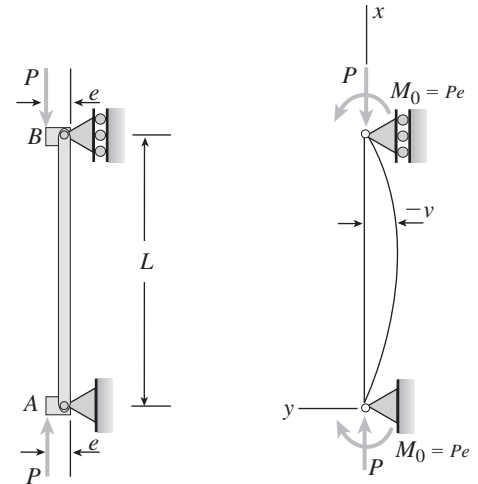

Probs. 11.5-3, 11.5-4, and 11.5-5

Solution 11.5-3 Column with eccentric loads

Column has pinned ends.

Use Eq. (11-49):

$$v = -e \left(\tan \frac{kL}{2} \sin kx + \cos kx - 1 \right)$$

From Eq. (11-45): $M = Pe - Pv$

$$\therefore M = Pe \left(\tan \frac{kL}{2} \sin kx + \cos kx \right) \quad \leftarrow$$

FOR $P = 0.3 P_{cr}$:

$$\begin{aligned} \text{From Eq. (11-52): } kL &= \pi \sqrt{\frac{P}{P_{cr}}} = \pi \sqrt{0.3} \\ &= 1.7207 \end{aligned}$$

$$\frac{M}{Pe} = \left(\tan \frac{1.7207}{2} \right) \left(\sin 1.7207 \frac{x}{L} \right) + \cos 1.7207 \frac{x}{L}$$

or

$$\frac{M}{Pe} = 1.162 \left(\sin 1.721 \frac{x}{L} \right) + \cos 1.721 \frac{x}{L} \quad \leftarrow$$

(Note: kL and kx are in radians)

BENDING-MOMENT DIAGRAM FOR $P = 0.3 P_{cr}$

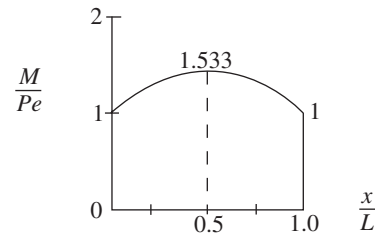

Problem 11.5-4 Plot the load-deflection diagram for a pinned-end column with eccentric axial loads (see figure) if the eccentricity e of the load is 5 mm and the column has length $L = 3.6$ m, moment of inertia $I = 9.0 \times 10^6 \text{ mm}^4$, and modulus of elasticity $E = 210 \text{ GPa}$.

Note: Plot the axial load as ordinate and the deflection at the midpoint as abscissa.

Solution 11.5-4 Column with eccentric loads

Column has pinned ends.

Use Eq. (11-54) for the deflection at the midpoint (maximum deflection):

$$\delta = e \left[\sec \left(\frac{\pi}{2} \sqrt{\frac{P}{P_{cr}}} \right) - 1 \right] \quad (1)$$

DATA

$$e = 5.0 \text{ mm} \quad L = 3.6 \text{ m} \quad E = 210 \text{ GPa}$$

$$I = 9.0 \times 10^6 \text{ mm}^4$$

CRITICAL LOAD

$$P_{cr} = \frac{\pi^2 EI}{L^2} = 1439.3 \text{ kN}$$

MAXIMUM DEFLECTION (FROM EQ. 1)

$$\delta = (5.0) [\sec (0.041404 \sqrt{P}) - 1] \quad (2)$$

Units: $P = \text{kN}$ $\delta = \text{mm}$
 angles are in radians.

SOLVE EQ. (2) FOR P :

$$P = 583.3 \left[\arccos \left(\frac{5.0}{5.0 + \delta} \right) \right]^2 \quad \leftarrow$$

LOAD-DEFLECTION DIAGRAM

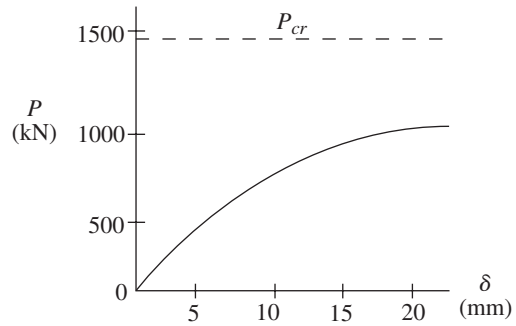

Problem 11.5-5 Solve the preceding problem for a column with $e = 0.20 \text{ in.}$, $L = 12 \text{ ft}$, $I = 21.7 \text{ in.}^4$, and $E = 30 \times 10^6 \text{ psi}$.

Solution 11.5-5 Column with eccentric loads

Column has pinned ends
 Use Eq. (11-54) for the deflection at the midpoint
 (maximum deflection):

$$\delta = e \left[\sec \left(\frac{\pi}{2} \sqrt{\frac{P}{P_{cr}}} \right) - 1 \right] \quad (1)$$

DATA

$e = 0.20 \text{ in.}$ $L = 12 \text{ ft} = 144 \text{ in.}$
 $E = 30 \times 10^6 \text{ psi}$
 $I = 21.7 \text{ in.}^4$

CRITICAL LOAD

$$P_{cr} = \frac{\pi^2 EI}{L^2} = 309.9 \text{ k}$$

MAXIMUM DEFLECTION (FROM EQ. 1)

$$\delta = (0.20) [\sec (0.08924 \sqrt{P}) - 1] \quad (2)$$

Units: $P = \text{kips}$ $\delta = \text{inches}$
 Angles are in radians.

SOLVE EQ. (2) FOR P :

$$P = 125.6 \left[\arccos \left(\frac{0.2}{0.2 + \delta} \right) \right]^2 \quad \leftarrow$$

LOAD-DEFLECTION DIAGRAM

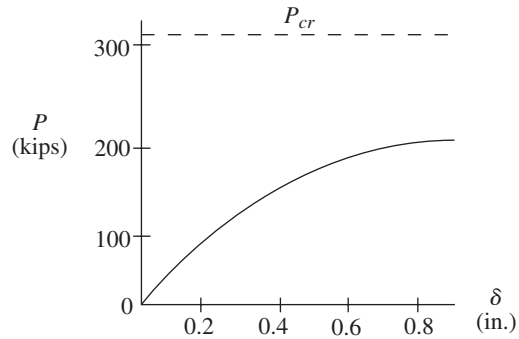

Problem 11.5-6 A wide-flange member ($W 8 \times 15$) is compressed by axial loads that have a resultant P acting at the point shown in the figure. The member has modulus of elasticity $E = 29,000 \text{ ksi}$ and pinned conditions at the ends. Lateral supports prevent any bending about the weak axis of the cross section.

If the length of the member is 20 ft and the deflection is limited to $1/4 \text{ inch}$, what is the maximum allowable load P_{allow} ?

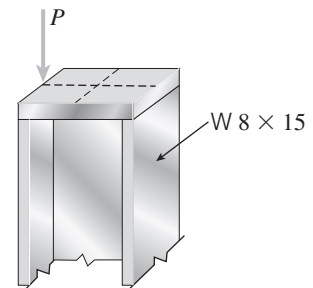

Solution 11.5-6 Column with eccentric axial load

Wide-flange member: W 8 × 15

 $E = 29,000$ psi $L = 20$ ft = 240 in.Maximum allowable deflection = 0.25 in. (= δ)

Pinned-end conditions

Bending occurs about the strong axis (axis 1-1)

From Table E-1: $I = 48.0$ in.⁴

$$e = \frac{8.11 \text{ in.}}{2} = 4.055 \text{ in.}$$

CRITICAL LOAD

$$P_{cr} = \frac{\pi^2 EI}{L^2} = 238,500 \text{ lb}$$

MAXIMUM DEFLECTION (EQ. 11-54)

$$\delta_{max} = e \left[\sec \left(\frac{\pi}{2} \sqrt{\frac{P}{P_{cr}}} \right) - 1 \right]$$

$$0.25 \text{ in.} = (4.055 \text{ in.}) [\sec(0.003216 \sqrt{P}) - 1]$$

Rearrange terms and simplify:

$$\cos(0.003216 \sqrt{P}) = 0.9419$$

$$0.003216 \sqrt{P} = \arccos 0.9419 = 0.3426$$

(Note: Angles are in radians)

$$\text{Solve for } P: \quad P = 11,300 \text{ lb}$$

ALLOWABLE LOAD

$$P_{allow} = 11,300 \text{ lb} \quad \leftarrow$$

Problem 11.5-7 A wide-flange member (W 10 × 30) is compressed by axial loads that have a resultant $P = 20$ k acting at the point shown in the figure. The material is steel with modulus of elasticity $E = 29,000$ ksi. Assuming pinned-end conditions, determine the maximum permissible length L_{max} if the deflection is not to exceed 1/400th of the length.

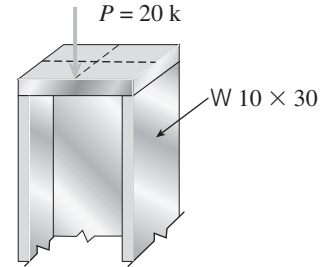
**Solution 11.5-7 Column with eccentric axial load**

Wide-flange member: W 10 × 30

Pinned-end conditions.

Bending occurs about the weak axis (axis 2-2).

 $P = 20$ k $E = 29,000$ ksi $L =$ length (inches)

$$\text{Maximum allowable deflection} = \frac{L}{400} \quad (= \delta)$$

From Table E-1: $I = 16.7$ in.⁴

$$e = \frac{5.810 \text{ in.}}{2} = 2.905 \text{ in.}$$

$$k = \sqrt{\frac{P}{EI}} = 0.006426 \text{ in.}^{-1}$$

DEFLECTION AT MIDPOINT (EQ. 11-51)

$$\delta = e \left(\sec \frac{kL}{2} - 1 \right)$$

$$\frac{L}{400} = (2.905 \text{ in.}) [\sec(0.003213 L) - 1]$$

Rearrange terms and simplify:

$$\sec(0.003213 L) - 1 - \frac{L}{1162 \text{ in.}} = 0$$

(Note: angles are in radians)

Solve the equation numerically for the length L :

$$L = 150.5 \text{ in.}$$

MAXIMUM ALLOWABLE LENGTH

$$L_{max} = 150.5 \text{ in.} = 12.5 \text{ ft} \quad \leftarrow$$

Problem 11.5-8 Solve the preceding problem ($W 10 \times 30$) if the resultant force P equals 25 k.

Solution 11.5-8 Column with eccentric axial load

Wide-flange member: $W 10 \times 30$
 Pinned-end conditions
 Bending occurs about the weak axis (axis 2-2)
 $P = 25 \text{ k}$ $E = 29,000 \text{ ksi}$ $L = \text{length (inches)}$

Maximum allowable deflection $= \frac{L}{400} (= \delta)$

From Table E-1: $I = 16.7 \text{ in.}^4$
 $e = \frac{5.810 \text{ in.}}{2} = 2.905 \text{ in.}$

$k = \sqrt{\frac{P}{EI}} = 0.007185 \text{ in.}^{-1}$

DEFLECTION AT MIDPOINT (EQ. 11-51)

$\delta = e \left(\sec \frac{kL}{2} - 1 \right)$

$\frac{L}{400} = (2.905 \text{ in.}) \left[\sec(0.003592L) - 1 \right]$

Rearrange terms and simplify:

$\sec(0.003592L) - 1 - \frac{L}{1162 \text{ in.}} = 0$

(Note: angles are in radians)

Solve the equation numerically for the length L :

$L = 122.6 \text{ in.}$

MAXIMUM ALLOWABLE LENGTH

$L_{\max} = 122.6 \text{ in.} = 10.2 \text{ ft} \quad \leftarrow$

Problem 11.5-9 The column shown in the figure is fixed at the base and free at the upper end. A compressive load P acts at the top of the column with an eccentricity e from the axis of the column.

Beginning with the differential equation of the deflection curve, derive formulas for the maximum deflection δ of the column and the maximum bending moment M_{\max} in the column.

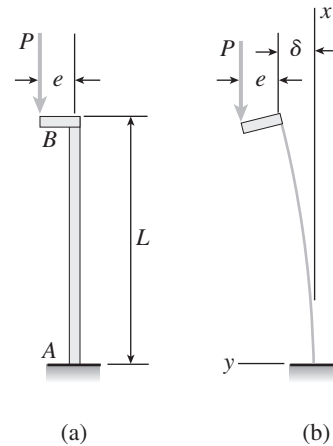

Solution 11.5-9 Fixed-free column

$e = \text{eccentricity of load } P$
 $\delta = \text{deflection at the end of the column}$
 $v = \text{deflection of the column at distance } x \text{ from the base}$

DIFFERENTIAL EQUATION (EQ. 11.3)

$EIv'' = M = P(e + \delta - v) \quad k^2 = \frac{P}{EI}$

$v'' = k^2(e + \delta - v)$

$v'' + k^2v = k^2(e + \delta)$

GENERAL SOLUTION

$v = C_1 \sin kx + C_2 \cos kx + e + \delta$

$v' = C_1 k \cos kx - C_2 k \sin kx$

B.C. 1 $v(0) = 0 \quad \therefore C_2 = -e - \delta$

B.C. 2 $v'(0) = 0 \quad \therefore C_1 = 0$

$v = (e + \delta)(1 - \cos kx)$

B.C. 3 $v(L) = \delta \quad \therefore \delta = (e + \delta)(1 - \cos kL)$
 or $\delta = e(\sec kL - 1)$

MAXIMUM DEFLECTION $\delta = e(\sec kL - 1) \quad \leftarrow$

MAXIMUM BENDING MOMENT (AT BASE OF COLUMN)

$M_{\max} = P(e + \delta) = Pe \sec kL \quad \leftarrow$

NOTE: $v = (e + \delta)(1 - \cos kx)$

$= e(\sec kL)(1 - \cos kx)$

Problem 11.5-10 An aluminum box column of square cross section is fixed at the base and free at the top (see figure). The outside dimension b of each side is 100 mm and the thickness t of the wall is 8 mm. The resultant of the compressive loads acting on the top of the column is a force $P = 50$ kN acting at the outer edge of the column at the midpoint of one side.

What is the longest permissible length L_{\max} of the column if the deflection at the top is not to exceed 30 mm? (Assume $E = 73$ GPa.)

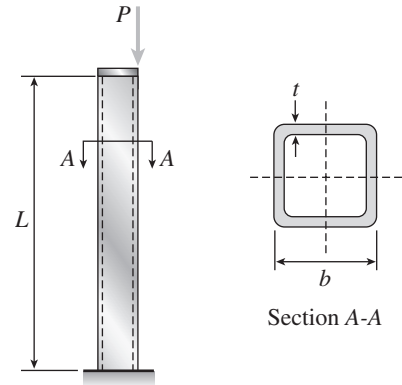

Probs. 11.5-10 and 11.5-11

Solution 11.5-10 Fixed-free column

δ = deflection at the top

Use Eq. (11-51) with $L/2$ replaced by L :

$$\delta = e(\sec kL - 1) \quad (1)$$

(This same equation is obtained in Prob. 11.5-9.)

SOLVE FOR L FROM EQ. (1)

$$\sec kL = 1 + \frac{\delta}{e} = \frac{e + \delta}{e}$$

$$\cos kL = \frac{e}{e + \delta} \quad kL = \arccos \frac{e}{e + \delta}$$

$$L = \frac{1}{k} \arccos \frac{e}{e + \delta} \quad k = \sqrt{\frac{P}{EI}}$$

$$L = \sqrt{\frac{EI}{P}} \arccos \frac{e}{e + \delta} \quad (2)$$

NUMERICAL DATA

$$E = 73 \text{ GPa} \quad b = 100 \text{ mm} \quad t = 8 \text{ mm}$$

$$P = 50 \text{ kN} \quad \delta = 30 \text{ mm} \quad e = \frac{b}{2} = 50 \text{ mm}$$

$$I = \frac{1}{12} [b^4 - (b - 2t)^4] = 4.1844 \times 10^6 \text{ mm}^4$$

MAXIMUM ALLOWABLE LENGTH

Substitute numerical data into Eq. (2).

$$\sqrt{\frac{EI}{P}} = 2.4717 \text{ m} \quad \frac{e}{e + \delta} = 0.625$$

$$\arccos \frac{e}{e + \delta} = 0.89566 \text{ radians}$$

$$L_{\max} = (2.4717 \text{ m})(0.89566) = 2.21 \text{ m} \quad \leftarrow$$

Problem 11.5-11 Solve the preceding problem for an aluminum column with $b = 6.0$ in., $t = 0.5$ in., $P = 30$ k, and $E = 10.6 \times 10^3$ ksi. The deflection at the top is limited to 2.0 in.

Solution 11.5-11 Fixed-free column

δ = deflection at the top

Use Eq. (11-51) with $L/2$ replaced by L :

$$\delta = e(\sec kL - 1) \quad (1)$$

(This same equation is obtained in Prob. 11.5-9.)

SOLVE FOR L FROM EQ. (1)

$$\sec kL = 1 + \frac{\delta}{e} = \frac{e + \delta}{e}$$

$$\cos kL = \frac{e}{e + \delta} \quad kL = \arccos \frac{e}{e + \delta}$$

$$L = \frac{1}{k} \arccos \frac{e}{e + \delta} \quad k = \sqrt{\frac{P}{EI}}$$

$$L = \sqrt{\frac{EI}{P}} \arccos \frac{e}{e + \delta} \quad (2)$$

NUMERICAL DATA

$$E = 10.6 \times 10^3 \text{ ksi} \quad b = 6.0 \text{ in.} \quad t = 0.5 \text{ in.}$$

$$P = 30 \text{ k} \quad \delta = 2.0 \text{ in.} \quad e = \frac{b}{2} = 3.0 \text{ in.}$$

$$I = \frac{1}{12} [b^4 - (b - 2t)^4] = 55.917 \text{ in.}^4$$

MAXIMUM ALLOWABLE LENGTH

Substitute numerical data into Eq. (2).

$$\sqrt{\frac{EI}{P}} = 140.56 \text{ in.} \quad \frac{e}{e + \delta} = 0.60$$

$$\arccos \frac{e}{e + \delta} = 0.92730 \text{ radians}$$

$$L_{\max} = (140.56 \text{ in.})(0.92730) = 130.3 \text{ in.} = 10.9 \text{ ft} \quad \leftarrow$$

Problem 11.5-12 A steel post AB of hollow circular cross section is fixed at the base and free at the top (see figure). The inner and outer diameters are $d_1 = 96 \text{ mm}$ and $d_2 = 110 \text{ mm}$, respectively, and the length $L = 4.0 \text{ m}$.

A cable CBD passes through a fitting that is welded to the side of the post. The distance between the plane of the cable (plane CBD) and the axis of the post is $e = 100 \text{ mm}$, and the angles between the cable and the ground are $\alpha = 53.13^\circ$. The cable is pretensioned by tightening the turnbuckles.

If the deflection at the top of the post is limited to $\delta = 20 \text{ mm}$, what is the maximum allowable tensile force T in the cable? (Assume $E = 205 \text{ GPa}$.)

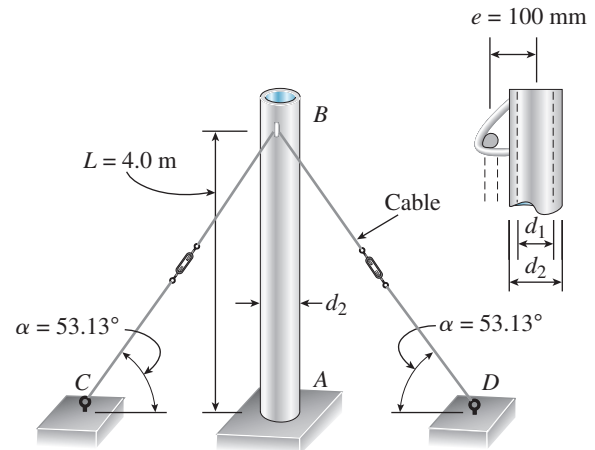

Solution 11.5-12 Fixed-free column

$\delta =$ deflection at the top

$P =$ compressive force in post $k = \sqrt{\frac{P}{EI}}$

Use Eq. (11-51) with $L/2$ replaced by L :

$$\delta = e(\sec kL - 1) \tag{1}$$

(This same equation is obtained in Prob. 11.5-9.)

SOLVE FOR P FROM EQ.(1)

$$\sec kL = 1 + \frac{\delta}{e} = \frac{e + \delta}{e}$$

$$\cos kL = \frac{e}{e + \delta} \quad kL = \arccos \frac{e}{e + \delta}$$

$$kL = \sqrt{\frac{PL^2}{EI}} \quad \sqrt{\frac{PL^2}{EI}} = \arccos \frac{e}{e + \delta}$$

Square both sides and solve for P :

$$P = \frac{EI}{L^2} \left(\arccos \frac{e}{e + \delta} \right)^2 \tag{2}$$

NUMERICAL DATA

$$E = 205 \text{ GPa} \quad L = 4.0 \text{ m} \quad e = 100 \text{ mm}$$

$$\delta = 20 \text{ mm} \quad d_2 = 110 \text{ mm} \quad d_1 = 96 \text{ mm}$$

$$I = \frac{\pi}{64} (d_2^4 - d_1^4) = 3.0177 \times 10^6 \text{ mm}^4$$

MAXIMUM ALLOWABLE COMPRESSIVE FORCE P

Substitute numerical data into Eq. (2).

$$P_{\text{allow}} = 13,263 \text{ N} = 13,263 \text{ kN}$$

MAXIMUM ALLOWABLE TENSILE FORCE T IN THE CABLE

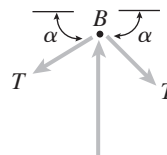

Free-body diagram of joint B :

$$\alpha = 53.13^\circ$$

$$\sum F_{\text{vert}} = 0 \quad P - 2T \sin \alpha = 0$$

$$T = \frac{P}{2 \sin \alpha} = \frac{5P}{8} = 8289 \text{ N}$$